



### Replacement Instructions

Follow the instructions in this sheet carefully. Failure to follow these instructions could damage your equipment and void its warranty.

**Note :** Written and video instructions covering customer-installable parts are available at <http://www.info.apple.com/install-parts/>.

**Warning :** Sharp edges can exist inside your computer and on any parts being removed or installed. Use caution to avoid injury.

**During this procedure, keep small parts away from children.**

### Tools Required

- Soft towel or cloth, larger than the PowerBook
- Torx T8 screwdriver

### Backing Up Your Data

**Warning :** Before replacing your hard drive, make sure you back up all data on the drive.

### Opening the Computer

**Warning :** Always shut down your computer before opening it to avoid damaging its internal components or causing injury. After you shut down the computer, the internal components can be very hot. Let the computer cool down before continuing.

To access the hard drive, you must first remove the battery and bottom case.

1. Place your computer on a clean, flat surface.
2. Shut down your computer and wait thirty minutes before continuing.
3. Disconnect the power cord and any other cables connected to the computer.
4. Place a towel or soft cloth on a table in front of you (**Figure 1A**).  
The towel or cloth will protect the keyboard and display area of the PowerBook when you flip it over to remove the battery and bottom case. Make sure it covers an area large enough for your PowerBook and that it hangs over the edge of the table.
5. With the display open at an angle greater than 90 degrees, carefully flip the PowerBook over and lay it flat, fully on the table. Make sure the display hangs over the edge of the table and rests lightly on your lap (**Figure 1B**).

**Important :** Do not open the display farther than the angle shown.

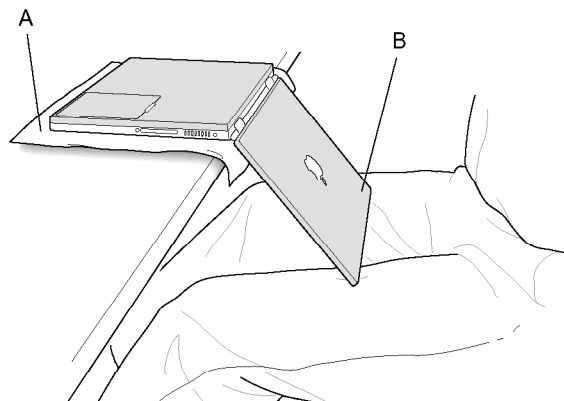
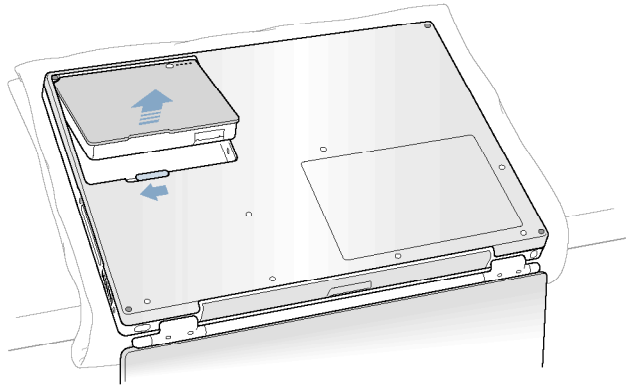

Figure 1

6. Remove the battery by sliding the battery latch to the left. Make sure to return the latch fully to the right (**Figure 2**). Removing the battery will prevent you from accidentally turning on the computer.

**Warning :** Removing the battery before shutting down your computer may result in data loss.

**Figure 2**



7. Use a Torx T8 screwdriver to remove the seven bottom case screws in the order shown (**Figure 3**).

**Important :** To avoid damaging the case, be careful that the screwdriver tip does not slip out of the screw head during removal.

**Figure 3**

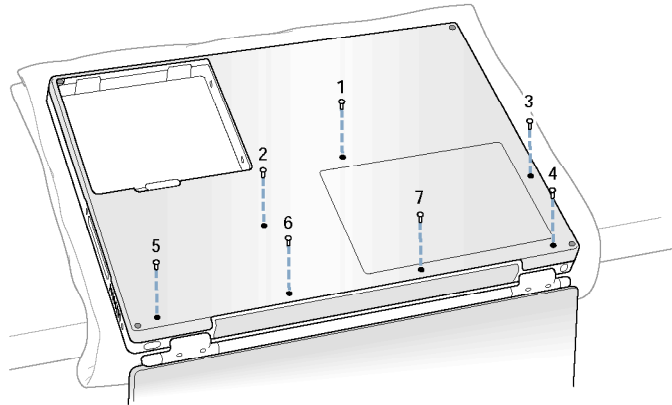

**Note :** In the following two steps you will disengage the left and right sides of the bottom case and then pivot it forward to remove.

8. Carefully slide the bottom case away from you (**Figure 4**).

**Important :** Do not push on the rubber feet of the bottom case.

**Figure 4**

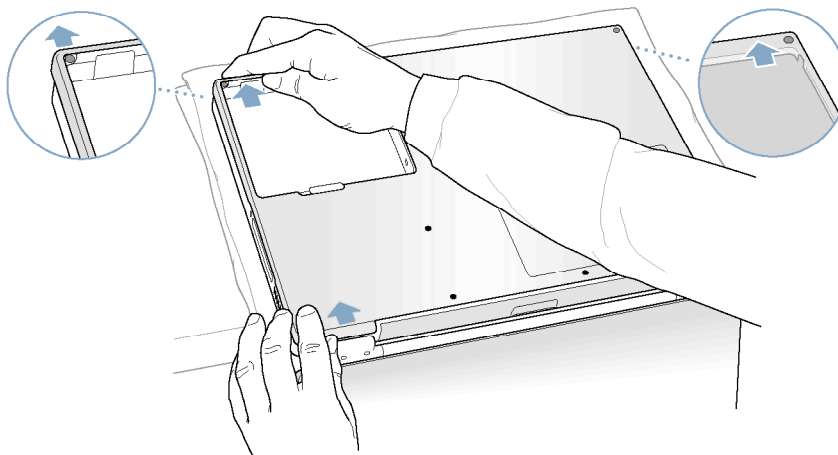

9. Pivot the bottom case up as shown (**Figure 5**).

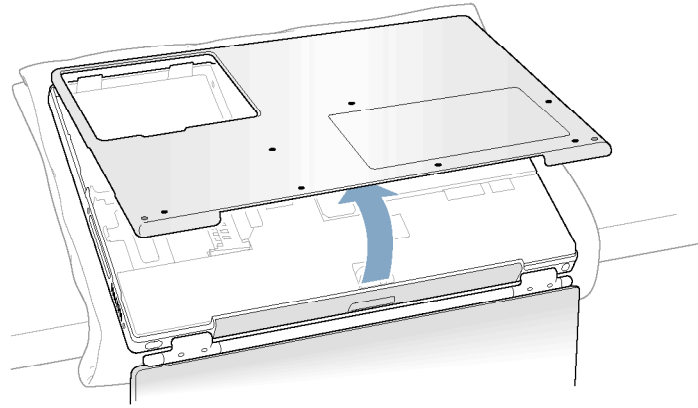

**Figure 5**

10. Touch the computer's inside framework (a dull gray conductive composite material) to discharge any static electricity, as shown (**Figure 6**).

**Important** : To avoid electrostatic discharge damage, always ground yourself by touching the computer's framework before you touch any parts or install any components inside the computer. To avoid static electricity building back up in your body, do not walk around the room until you have completed your installation and closed the computer.

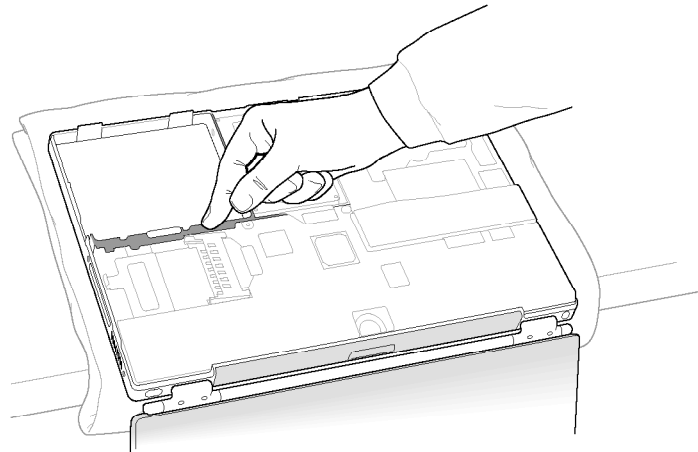

**Figure 6**

### Removing the Installed Hard Drive

1. With your fingers, carefully pry up the hard drive cable connector (**Figure 7A**) at its sides to disconnect it from the logic board. You may need to pry one side, then the other, in a rocking motion.

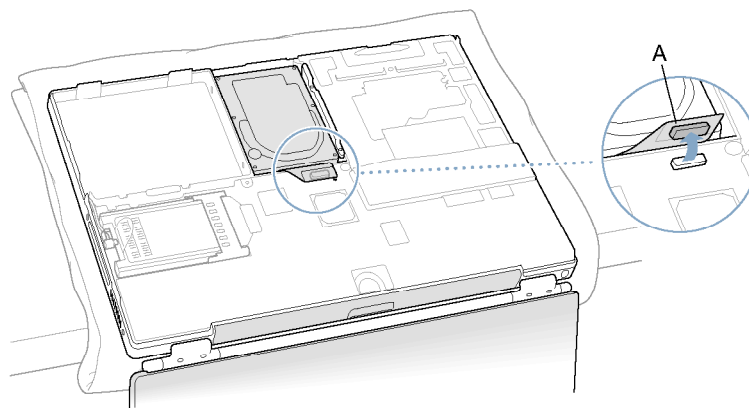

**Figure 7**

2. With a Torx T8 screwdriver, remove the two screws that secure the hard drive mounting bracket, and remove the bracket (**Figure 8**).

**Figure 8**

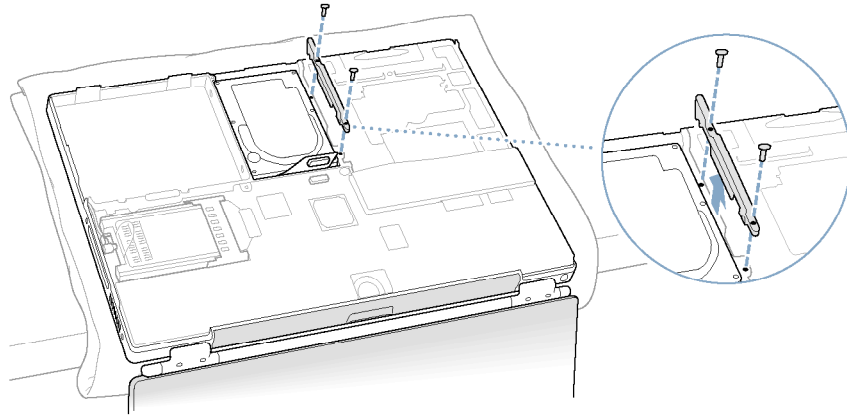

3. Pull up on the right side of the hard drive to remove it (**Figure 9**).

**Important** : Do not pull on the connector cable or use the cable as a handle.

**Figure 9**

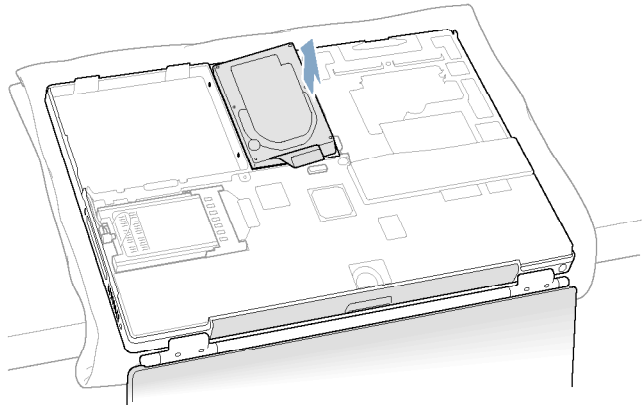

**Note** : There are four rubber stoppers on the hard drive that fit over screws (two on each side). Remove any that may have fallen off or that remain in the holes in the mounting bracket inside the computer.

4. If not included with the replacement drive, remove the Mylar sheath and the flex cable to transfer to the replacement drive.

**Important** : The connector pins on the hard drive are fragile and bend easily. Use care to keep the pins straight when removing or installing the flex cable.

## Installing the Replacement Hard Drive

**Warning :** To avoid potential injury or damage, avoid touching the thin strip of metal that extends up from the rib frame at the battery well.

**Important :** Avoid touching the optical drive as you perform this procedure.

1. Make sure that the screws (**Figure 10A**) and rubber stoppers (**Figure 10B**) are in place on the sides of the replacement drive.
2. Install the Mylar sheath (**Figure 10C**) so that it covers the bottom and left and right sides of the drive. The sheath is directional and must be installed in the direction that does not extend beyond the front of the drive.
3. Carefully install the hard drive cable, if needed (**Figure 10D**). The cable connector is keyed to fit only one way.

**Figure 10**

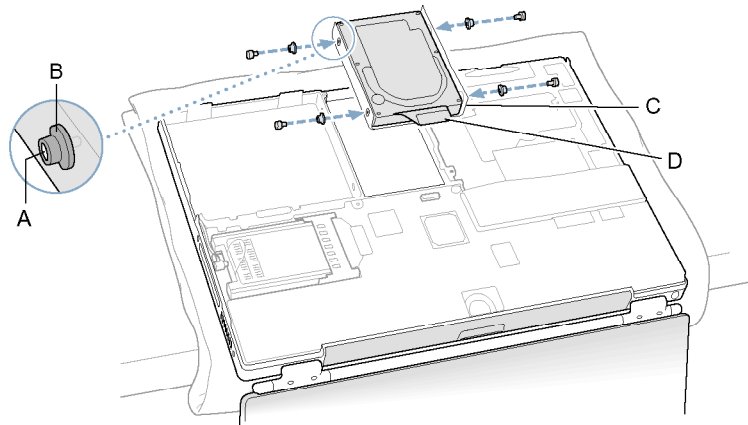

4. Insert the left side of the drive first, then the right. Use a screwdriver through the frame holes on the left side to help align the stoppers, as necessary (**Figure 11**).

**Figure 11**

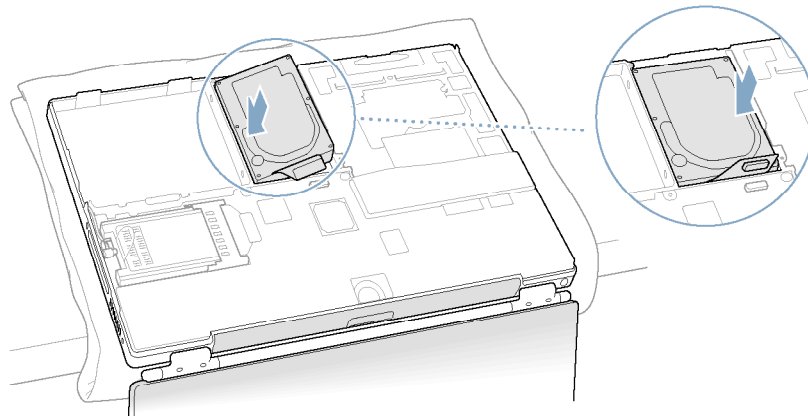

5. Replace the hard drive mounting bracket and secure with the screws (**Figure 12**).

**Important** : Check that the rubber stoppers and Mylar sheath are not pinched by the bracket.

**Figure 12**

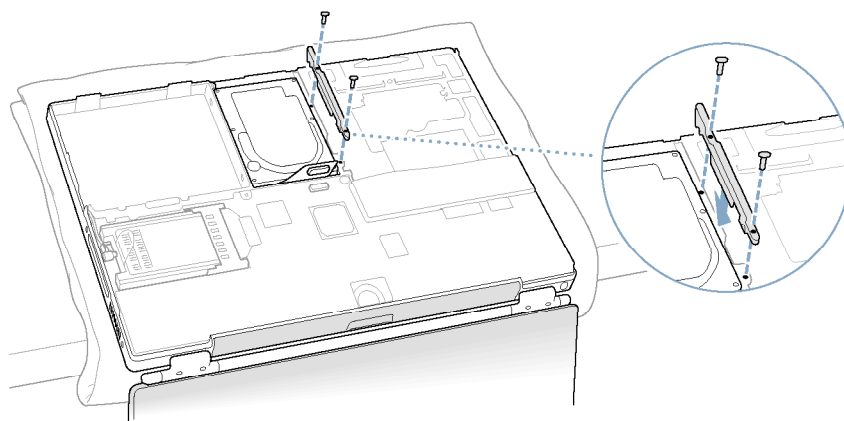

6. Connect the hard drive cable connector (**Figure 13**) to the logic board.

**Figure 13**

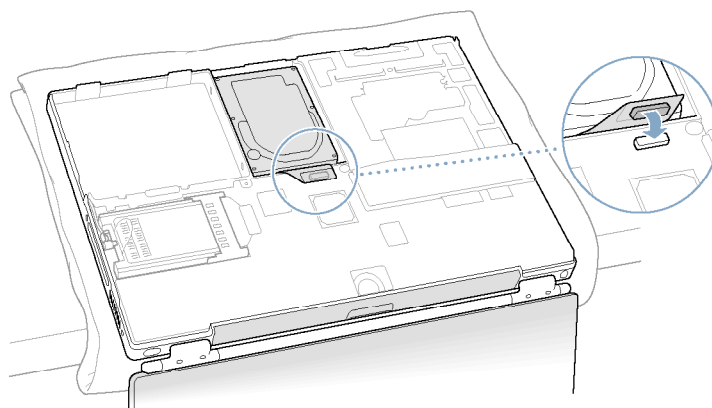

## Closing the computer

1. To attach the new bottom case, align the notches on the right and left sides of the case, then press down slightly to secure the case. Check the alignment of the seven screw holes to make sure the bottom case is properly positioned.

**Important :** Make sure that the seams between the bottom case and the frame are closed. Check the outside edges and around the battery well. Verify that the alignment tab on the underside of the bottom case (**Figure 14A**) has seated, and the case lies flat.

2. Replace the seven screws in the order shown in the illustration (**Figure 14**).

**Note :** The screws must go in straight and easily ; if they do not, readjust the bottom case for proper alignment. Do not overtighten the screws or damage could result.

**Important :** To avoid damaging the case, be careful that the screwdriver tip does not slip out of the screw head during tightening.

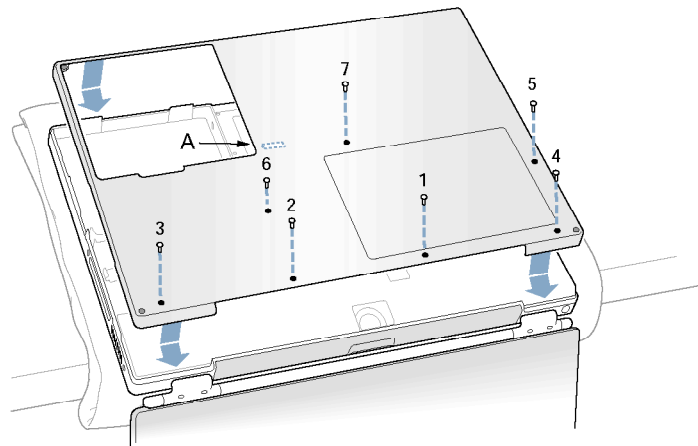

Figure 14

3. Replace the battery (**Figure 15**).

**Important :** Make sure that the battery locks securely into place and that the battery latch is slid all the way into the locked position.

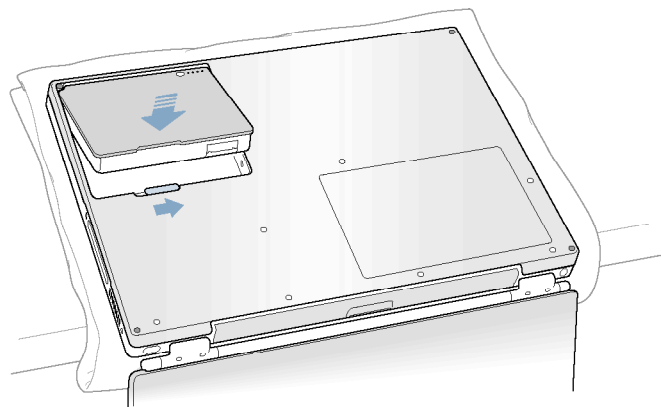
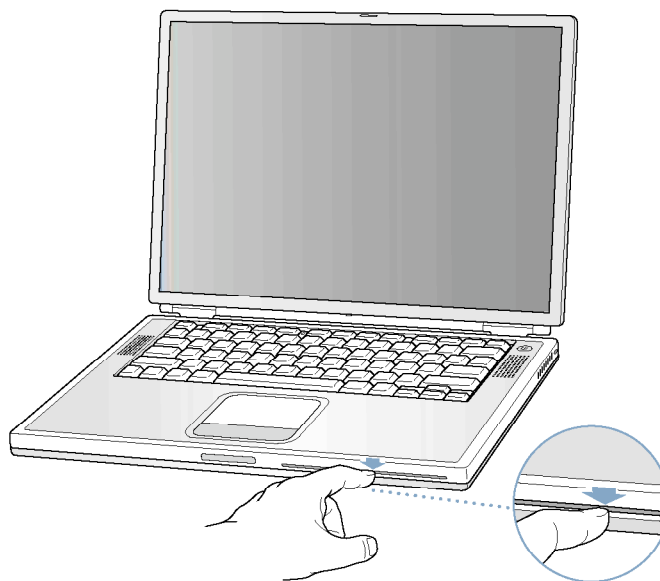

Figure 15

4. Turn the computer over. Look at the optical drive slot to make sure that the case is properly secured. If a gap exists below the slot, gently pull the bottom of the optical drive slot toward you until it clicks into place and the gap is removed (**Figure 16**).

**Figure 16**



5. Reconnect the power cord and any other cables that were connected, and restart your computer.

**Warning : Never turn on your computer unless all of its internal and external parts are in place and it is closed. Operating the computer when it is open or missing parts can damage your computer or cause injury.**

🍏 Apple Computer, Inc.

© 2002 Apple Computer, Inc. All rights reserved.

Under the copyright laws, this document may not be copied, in whole or in part, without the written consent of Apple.

The Apple logo is a trademark of Apple Computer, Inc., registered in the U.S. and other countries. Use of the "keyboard" Apple logo (Option-Shift-K) for commercial purposes without the prior written consent of Apple may constitute trademark infringement and unfair competition in violation of federal and state laws.

Every effort has been made to ensure that the information in this document is accurate. Apple is not responsible for printing or clerical errors.

Apple Computer, Inc.  
1 Infinite Loop  
Cupertino, CA 95014-2084  
USA  
+ 1 408 996 1010  
<http://www.apple.com>

Apple, the Apple logo, and PowerBook are trademarks of Apple Computer, Inc., registered in the U.S. and other countries.